

W-5
June -23

**PROCUREMENT OF CIVIL WORKS
UNDER
NATIONAL SHOPPING PROCEDURES**

FOR

CONSTRUCTION OF 250 Sq Mt PROCESSING SHED

FOR

**MANDHAL AGRO PRODUCT FARMERS PVT LTD
AT-MANDHAL TA-KUHI DIST-NAGPUR**

UNDER

**Hon. Balasaheb Thackeray Agribusiness Rural Transformation
(SMART) Project**

TENDER NOTICE

Hon. Balasaheb Thackeray Agri-business & Rural Transformation Project (SMART)

Govt. of Maharashtra is implementing World Bank assisted Hon. Balasaheb Thackeray Agribusiness And Rural Transformation (SMART) Project for developing Agriculture Commodity value chains. Mandhal Agro Product Farmers Pvt Ltd At-Mandhal Ta-Kuhi Dist-Nagpur is one of the beneficiaries under the project and inviting bids for the following works.

Name of work (Components)	Estimated Tender Amount in Rs.	Tender fee Rs.	EMD	Period of Completion in Months
CONSTRUCTION OF 250 Sq Mt PROCESSING SHED	44.32 Lakh	Rs 500 + 90 (18% GST) = Rs.590/-	Submission of bid security declaration	11 Months
Sale of tender document		From 07-07-2023 To 07-08-2023 up to 3:00PM		
Date & Time of Pre-bid meeting		20-07-2023 at 12:00 PM		
Tender Submission end date & time		07-08-2023 up to 3.00PM		
Technical bid opening date & time		07-08-2023 at 3.30PM		

Bid document is available at the following office address and also on project website <https://www.smart-mh.org>. For further any updates / notices shall be published on project website only._____

Sd/-

President

(Mr.PRASAD HARIBHAU TIDKE)

MANDHAL AGRO PRODUCT FARMERS PVT LTD

AT-MANDHAL TA-KUHI DIST-NAGPUR

Mob :9270288657 Email ID: prasadtidke287@gmail.com

INVITATION FOR QUOTATIONS FOR
CONSTRUCTION OF 250 Sq Mt PROCESSING SHED

Date:05/07/2023

RFQ No.: SMART/Mandhal APFCL/Works/10 /2022-23

To

Sub: Invitation For Quotations for Proposed Construction work for Construction Of 250 Sq Mt Processing Shed

Dear Sirs,

- 1) Govt. of Maharashtra is implementing World Bank assisted Hon. Balasaheb Thackeray Agribusiness And Rural Transformation (SMART) Project for developing Agriculture Commodity value chains. Project is extending up to 60% grants in the form of Viability Gap Fund (VGF) to eligible Community Based Organizations (CBO).
- 2) The SMART Project is being implemented by various Project Implementation Units. PIU Agriculture is one of the implementing unit of SMART Project. Mandhal Agro Product Farmers Pvt Ltd At-Mandhal Ta-Kuhi Dist-Nagpur is one of the beneficiaries of PIU Agriculture under the SMART project.
- 3) Mandhal Agro Product Farmers Pvt Ltd At-Mandhal Ta-Kuhi Dist-Nagpur (hereinafter referred to as employer) is inviting quotation for the following work under the SMART Project.
- 4) You are invited to submit your most competitive quotation for the following works:-

Sr. No.	Brief Description of the Works	Approximate Value of Work (in Rs.)	Period of completion
1	Construction Of 250 Sq Mt Processing Shed	44.32 Lakh	11 Months

- 5) To assist you in the preparation of your quotation, we are enclosing the following:
 - a) Layout Drawings of the works;
 - b) Detailed Bill of Quantities,
 - c) Technical Specifications;
 - d) Instructions to Bidders (in two sections).
 - e) Draft Contract Agreement format which will be used for finalizing the agreement for this Contract.
 - f) Structural Design
- 6) You are requested to provide your offer latest by **3:00 pm on 07/08/2023**
- 7) Technical bid will be opened in the presence of bidders or their representatives who choose to attend at **3:00 pm on 07/08/2023** in the office of Mandhal Agro Product Farmers Pvt Ltd At-Mandhal Ta-Kuhi Dist-Nagpur
- 8) We look forward to receiving your quotations and thank you for your interest in this project.

President, Procurement Committee

Name: (Mr.PRASAD HARIBHAU TIDKE)

Office Address: Mandhal Agro Product Farmers Pvt Ltd At-Mandhal Ta-Kuhi Dist-Nagpur

Mob :9270288657 **Email ID:** prasadtidke287@gmail.com

Instructions to Bidders

SECTION - A

1. Scope of Works:

Mandhal Agro Product Farmers Pvt Ltd invites quotations for the construction of works as detailed in the table given below

Sr. No.	Brief Description of the Works	Approximate Value of Work (in Rs.)	Period of completion
1	Construction Of 250 Sq Mt Processing Shed	44.32 Lakh	11 Months

The successful bidder will be expected to complete the works by the intended completion date specified above.

2. Qualification of the bidder:

The bidder shall provide qualification information which shall include:-

- total monetary value of construction works performed for each year of the last 5 years;
- Report on his financial standing; (Turn over certificate issued by Chartered Accountant for last five years); and
- Details of any litigation, current or during the last 3 years in which the bidder is involved, the parties concerned and disputed amount or awards in each case.
- Should possess valid license for executing civil works as per appropriate class issued by central or state PWD or any government department.

3. To qualify for award of the contract the bidder:-

The bidder should fulfill following all qualification criteria;

- Should have GST registration
- Should possess valid license for executing civil works as per appropriate class issued by central or state PWD or any government department.
- should have achieved in at least one year an annual financial turnover of value not less than **Rs.44.32 Lakhs** in the last five years i.e. during FY 2017-18 to 2021-22 OR FY 2018-19 to 2022-23;
- Experience of having successfully completed similar works during last 5 years ending last day of month previous to the one in which bid is invited
 - Three similar completed works each costing not less than the amount equal to **Rs 18.00 lakhs** OR
 - Two similar completed works each costing not less than the amount equal to **Rs. 23.00 lakhs** OR
 - One similar completed work costing not less than the amount equal to **Rs. 36.00 lakhs**
- Should not have been black listed, debarred or suspended on the date of bid opening by any of the Government organization, the World Bank Group.

- f) * should possess valid electrical license for executing building electrification works (in the event of the works being sub-contracted, the sub-contractor should have the necessary license);
- g) No contract should have been suspended or terminated and/or performance security called by an employer(s) for reasons related to Environmental, Social (including sexual exploitation and abuse (SEA) and gender-based violence (GBV)), Health, or Safety (ESHS) requirements or safeguards in the past five years.
- h) Should not have Conflict of Interest as mentioned in the ITB 4.

4. Conflict of Interest:

Any Bidder found to have a conflict of interest shall be disqualified. A Bidder may be considered to have a conflict of interest for the purpose of this bidding process, if the Bidder:

- a) directly or indirectly controls, is controlled by or is under common control with another Bidder; or
- b) receives or has received any direct or indirect subsidy from another Bidder; or
- c) has the same legal representative as another Bidder; or
- d) has a relationship with another Bidder, directly or through common third parties, that puts it in a position to influence the bid of another Bidder, or influence the decisions of the Employer regarding this bidding process; or
- e) any of its affiliates has been hired (or is proposed to be hired) by the Employer or Borrower as Engineer for the Contract implementation;
- f) has a close business or family relationship with the concerned professional staff of the Borrower or of the project implementing agency.

(*for further details refer to paragraphs 3.14 and 3.15 of the “Procurement Regulations” setting forth the World Bank’s policy on conflict of interest)

5. Bid Price

- a) The contract shall be for the whole works as described in drawings and technical specifications. Corrections, if any, shall be made by crossing out, initialing, dating, and rewriting.
- b) The rate/price should be inclusive of all duties, GST, and other levies payable by the contractor under the contract
- c) The rates quoted by the bidder shall be fixed for the duration of the contract and shall not be subject to adjustment on any account.
- d) The bidder shall fill in the prices for the Works in conformity with the bidding documents, both in figures and words.
- e) Bidder need to quote for all the items mentioned in the BOQ. If bidder failed to quote for any or more items given in the BOQ and if bidder is selected, in such case bidder has to complete the work of the said item/items without any cost.

6. Validity of Quotation

Quotation shall remain valid for a period not less than 90 days after the deadline date specified for submission.

7. Tender Fee & Bid Security:

a) Tender Fee:

Bidding document should be purchased from the Employer office for a non-refundable fee as indicated. Bidder may also download bidding document from aforesaid website and submit bid document cost in the form of demand draft along with the bid. If bidder fails to submit the tender fee, the bid submitted by such bidder shall be rejected.

b) Bid Security :

- 1) Bidder should submit bid security declaration in the attached format. If bidder not submitted bid security declaration, the bid submitted by such bidder shall be rejected.
- 2) The Bid Security declaration shall be executed
 - a) if a bidder withdraws its bid prior to the expiry date of bid validity specified by the bidder on the letter of bid or any extended date provided by the bidder; or
 - b) During the bid process, if any information submitted found manipulated / hidden / false / mala fide in the bid
 - c) if the successful Bidder fails to
 - (i) sign the Contract or
 - (ii) furnish a Performance Security

8. Submission of bid.

- a) The bidder is advised to visit the site at his own expense and obtain all information that may be necessary for preparing the bid.
- b) Each bidder shall submit only one bid.
- c) Modification and Withdrawal of Bids – Resubmission of bid by the bidders for any number of times before the final date and time of submission is allowed.
- d) Bid shall comprise of the following 2 envelopes:
 - 1) **Envelope 1:** Technical bid
 - 2) **Envelope 2:** Financial /price bid

Note: The above both the envelopes are to be submitted in a separate sealed envelope mentioning the Technical bid and financial bid on top of the each envelop and bidders name at bottom of the envelope. Both these two envelopes shall be packed in a one outer envelope & seal it.

The sealed outer envelope will also bear the following identification: -

- Bid for Construction Of 250 Sq Mt Processing Shed
- Bidder's name.....
- Bidder's address
- Bidder's contact number

1) Technical bid: (Envelop 1)

The bidder shall submit following documents in the technical envelope.

- 1) Demand draft towards tender document fee if tender document downloaded from the website OR payment receipt if tender document purchased from the employer office.
- 2) Details of technical documents submitted (form no 1)
- 3) Qualification information in the format (Form -2)

- 4) Bid security declaration (Form-3)
- 5) The declaration that the bidder is not black listed/banned by any Government department / Public Sector Undertaking/ Private Sector/ or any other agency (form no 4)
- 6) Declaration about not have Conflict of Interest as mentioned in the ITB 4. (Form No 5)
- 7) Turn over certificate issued by the Chartered Accountant (Form-6)
- 8) Contractor registration certificate of appropriate class issued by the any Government organization.
- 9) GST registration certificate
- 10)* valid electrical license for executing building electrification works(self or sub-contractor)

2) Financial Bid: (Envelop 2)

The bidder shall quote for all items given in the attached quotation format only (Form no 7 & 8).

9. Bid opening and Evaluation process:

a) Opening of Envelop - A (Technical Bid)

The 'Technical Envelop' of bids will be publicly opened first in the presence procurement committee members and bidders' designated representatives and anyone who chooses to attend at the address on the date and time specified in the tender notice. In the event of the date specified for bid opening being declared as a closed holiday for the purchaser's office, the due date for opening of bids will be the following working day at the same time and venue.

b) Evaluation of Technical Bid

The evaluation of the technical bids will be carried out as per the eligibility criteria mentioned in the clause 3. The bidders fulfilling minimum eligibility criteria are declared technically qualified and eligible opening of the financial proposal.

c) Opening of Envelop - 2 (Financial Bid)

Financial envelope of technically qualified bidders shall be opened in the presence procurement committee members and bidders' designated representatives on the date and time informed by the purchaser.

10. Correction of Arithmetical Errors

1. If the bid is substantially responsive, the Purchaser shall correct arithmetical errors on the following basis:
 - (a) if there is a discrepancy between the unit price and the line item total that is obtained by multiplying the unit price by the quantity, the unit price shall prevail and the line item total shall be corrected, unless in the opinion of the Purchaser there is an obvious misplacement of the decimal point in the unit price, in which case the line item total as quoted shall govern and the unit price shall be corrected;
 - (b) if there is an error in a total corresponding to the addition or subtraction of subtotals, the subtotals shall prevail and the total shall be corrected; and

- (c) if there is a discrepancy between words and figures, the amount in words shall prevail, unless the amount expressed in words is related to an arithmetic error, in which case the amount in figures shall prevail subject to (a) and (b) above.
- 2. Bidders shall be requested to accept correction of arithmetical errors. Failure to accept the correction shall result in the rejection of the Bid.

11. Evaluation of Financial bids/ Quotations

To evaluate a bid, the Purchaser shall consider the following:

- (a) Financial evaluation will be done for all items together
- (b) Price adjustment for correction of arithmetic errors in accordance with ITB 10.
- (c) By applying the above evaluation criteria, the Purchaser shall determine the Most Advantageous Bid. This is the bid of the bidder that meets the qualification criteria and whose bid has been determined to be:
 - (a) Substantially responsive to the bidding document; and
 - (b) the lowest evaluated cost.

12. Information relating to evaluation of bids and recommendations for the award of contract shall not be disclosed to bidders or any other persons not officially concerned with the process until the award to the successful bidder is announced.

13. Award of contract:

- a) The Employer will award the contract to the bidder whose quotation has been determined to be substantially responsive and who has offered the lowest evaluated quotation price and who meets the specified qualification criteria.
- b) Notwithstanding the above, the Employer reserves the right to accept or reject any quotations and to cancel the bidding process and reject all quotations at any time prior to the award of contract.
- c) The bidder whose bid is accepted will be notified of the award of contract by the Employer prior to expiration of the quotation validity period.

14. Performance Security:

Within 15 days of receiving letter of acceptance, the successful bidder shall deliver to the employer the performance security in the form of Demand draft in favor of the employer for an amount equivalent of 3 % of the contract price.

15. Period of Maintenance:

The "Period of Maintenance" for the work is Twelve months from the date of taking over possession or one full monsoon season whichever occurs later. During the period of maintenance, the contractor will be responsible for rectifying any defects in construction free of cost to the Employer.

16. Purchase of all construction materials including cement and steel as per the specifications (ISI certification marked goods wherever available) shall be the responsibility of the contractor.

SECTION - B

1. Format for Qualification Information.
2. Format for Submission of Quotation.
3. Format of Letter of Acceptance.

Details of technical documents submitted

(On bidder's letter head)

Sr. No.	List of documents to be submitted	Document page No
1	Tender fee receipt	
2	Qualification Information (form no 2)	
3	Bid security declaration (Form no 3)	
4	The declaration that the bidder is not black listed/banned by any Government department/ Public Sector Undertaking/ Private Sector/ or any other agency (form no 4)	
5	Declaration about not have Conflict of Interest as mentioned in the ITB 3. (Form No 5)	
6	Turn over certificate issued by the chartered Accountant or copy of ITRs or balance sheet	
7	Valid license for executing civil works as per appropriate class issued by central or state PWD or any government department	
8	GST registration certificate	
9	Valid electrical license for executing building electrification works (if applicable)	

Signature

Name of Authorized Signatory.....

Bidder's Office Seal

Note: Bidders should submit this form along with all above mentioned required documents. Each document should be numbered. Employer reserves the right to reject the bid if any of the required documents are not submitted by the bidder along with the bid.

QUALIFICATION INFORMATION

1 For Individual Bidders

1.1 Principal place of business: _____

Power of attorney of signatory of Bid.

[Attach copy]

1.2 Total value of Civil** Engineering construction work performed in the last five years (in Rs. Lakhs)

2018-19:
 2019-20:.....
 2020-21:.....
 2021-22:.....
 2022-23:.....
 2023-24:.....

1.3 Work performed as prime contractor (in the same name) on works of a similar nature over the last five years.

Project Name	Name of Employer	Description of work	Contract No.	Value of contract (Rs. Lakhs)	Date of issue of work order	Stipulated period of completion	*Actual date of completion	Remarks explaining reasons for delay and work completed
1	2	3	4	5	6	7	8	9

*Completion certificate of Concern Engineer/ authorized person of client should be submitted along with the bid document.

Existing commitments and on-going works:

Description of Work	Place & State	Contract No. & Date	Value of Contract (Rs. Lakh)	Stipulated period of completion	Value of works ** remaining to be completed (Rs. Lakhs)	Anticipated date of completion
(1)	(2)	(3)	(4)	(5)	(6)	(7)

** Certificate of concern engineer /authorized person of client should be submitted along with the bid document

1.4 Proposed subcontracts and firms involved.

Sections of the works	Value of Sub-contract	Sub-contractor (name & address)	Experience in similar work

1.5 Evidence of access to financial resources to meet the requirement of working capital: cash in hand, lines of credit, etc. List them below and attach copies of supporting documents.

Particulars	Amount	Details
Cash in hand		
Availability of Cash flow		
Other source of fund if any		

1.6 Name, address, and telephone, telex, and fax numbers of the Bidders' bankers who may provide references if contacted by the Employer.

Name of Bank	Detailed Address	Contact No

1.7 Information on litigation history in which the Bidder is involved.

Other party(ies) 1	Employer 2	Cause of dispute 3	Amount involved 4	Remarks showing present status 5

If there is NO any litigation, then mention NIL.

If YES then mentioned the details column 3 and status in column 5

1.8 Contract(s) suspended or terminated and/or Performance Security called by an employer(s) for reasons related to Environmental, Social (including sexual exploitation and abuse (SEA) and gender-based violence (GBV)), Health, or Safety (ESHS) performance during the last five years. *(If YES, mention details in the following format)*

Contract(s) suspended or terminated by an Employer(s)
--

Year	Contract Identification, Name and address of the Employer, and reasons for suspension or termination	Amount of suspended or terminated portion of contract (Rs)	Total Contract Amount (Rs)
Performance Security called by an employer(s)			
Year	Contract Identification, Name and address of the Employer, and reasons for calling of performance security		Total Contract Amount (Rs)

Signature

Name of Authorized Signatory.....

Bidder's Office Seal

BID SECURITY DECLARATION
(To be submitted on the Bidder's Letter Head)

Date: 05/07/2023

RFQ Ref No.: SMART/Mandhal APFCL/Works/10/2022-23

To:

PRESIDENT
MANDHAL AGRO PRODUCT FARMERS PVT LTD
AT-MANDHAL TA-KUHI DIST-NAGPUR

We, the undersigned, declare that:

We understand that, according to your conditions, quotation must be supported by a Bid-Securing Declaration.

We accept that we will automatically be suspended from being eligible for bidding in any contract with any CBO or project implementing unit under SMART or various offices under various Government organization / World Bank funded Projects for the period of 3 years starting from opening of the financial bids, if we are in breach of our obligation(s) under the bid conditions, because we:

- (a) have withdrawn our Bid during the period of bid validity or
- (b) having been notified of the acceptance of our Bid by the employer during the period of bid validity, (i) fail or refuse to execute the Contract, if required, or (ii) fail or refuse to furnish the Performance Security in accordance with the clauses of Request for Quotation.

We understand this Bid-Securing Declaration shall expire if we are not the successful Bidder, upon the earlier of (i) our receipt of your notification to us of the name of the successful Bidder; or (ii) twenty-eight days after the expiration of our Bid.

Signature:

Name of person signing bid-security declaration:

Designation:

Name of Bidder:

Date:

Bidder's office Seal:

**FORMAT OF SELF DECLARATION WITH REGARD TO BLACKLISTING/ NON-
DEBARMENT & ESHS**
(To be submitted on the Bidder's Letter Head)

Date: 05/07/2023

Tender Ref No.: SMART/Mandhal APFCL/Works/10/2022-23

To:

PRESIDENT
MANDHAL AGRO PRODUCT FARMERS PVT LTD
AT-MANDHAL TA-KUHI DIST-NAGPUR

We hereby confirm and declare that we, M/s -----,
is not blacklisted/ De-registered/ debarred by any Government department /Public
Sector Undertaking/ Private Sector/ or any other agency for which we have Executed/
Undertaken the supply goods/ works/ Services during the last 3 years.

We also confirm and declare that no contract should have been suspended or
terminated and/or performance security called by an employer(s) for reasons related to
Environmental, Social (including sexual exploitation and abuse (SEA) and gender-based
violence (GBV)), Health, or Safety (ESHS) requirements or safeguards in the past 5 years.

Signature

Name of Authorized Signatory.....

Bidder's Office Seal

FORMAT OF SELF DECLARATION: NOT HAVE CONFLICT OF INTEREST
(To be submitted on the Bidder's Letter Head)

Date: 05/07/2023

Tender Ref No.: SMART/Mandhal APFCL/Works/10/2022-23

To:

PRESIDENT
MANDHAL AGRO PRODUCT FARMERS PVT LTD
AT-MANDHAL TA-KUHI DIST-NAGPUR

We hereby confirm and declare that we, M/s -----,
not have Conflict of Interest as mentioned in the ITB 4. We undertake that we shall be
liable for any punitive action in case of false declaration.

Signature

Name of Authorized Signatory.....

Bidder's Office Seal

**TURNOVER CERTIFICATE ISSUED BY CHARTERED ACCOUNTANT FIRM
(on CA's letter head)**

TO WHOMSOEVER IT MAY CONCERN

This is to certify that M/s. (name of bidder) is having registered office at (detailed office address). The turnover of the (name of firm) for the following financial years based on the audited financial Statement is as under.

Sr. No.	Financial Year	Turnover in lakhs
1		
2		
3		
4		
5		

The above information/figures are true and authentic to the best of my knowledge and belief. I/we am/ are well aware of the fact that furnishing of any false information/fabricated document would lead to rejection of bid or at any stage, besides liabilities towards prosecution under appropriate law.

Signature of the Chartered Accountant

Name of the Firm

Registration No.

Date:

Place:
(Seal of the Chartered Accountant)

Email id:

UDIN:

Note:

1. *Turnover certificate without UDIN shall be rejected.*
2. *Turnover from unaudited financial statement shall not be considered*

**LETTER OF QUOTATION
(On Bidders Letter head)**

RFQ No: SMART/Mandhal APFCL/Works/10/2022-23 Date-05/07/2023
Date of Quotation Submission:

To:
PRESIDENT
MANDHAL AGRO PRODUCT FARMERS PVT LTD
AT-MANDHAL TA-KUHI DIST-NAGPUR

Subject: Submission of Quotation for Construction of CONSTRUCTION OF 250 Sq Mt
PROCESSING SHED

Sir,
We have no reservations to the Invitation for Quotation Document, and offer to execute the Works referred above in accordance with the Conditions of Contract enclosed therewith at a Total Contract Price of –

Rs. _____ [in figures]
Rs. _____ [in words].

This quotation and your written acceptance of it shall constitute a binding contract between us. We understand that you are not bound to accept the lowest or any quotation you receive.

We hereby certify that we have taken steps to ensure that no person acting for us or on our behalf engages in any type of Fraud and Corruption.
We confirm that we bound to comply with (i) the applicable Laws/ Rules/ Regulations for protection of environment, public health and safety; (ii) the regulatory authority conditions (if any) attached to any permits or approvals for the project;

We confirm that, if our quotation is accepted, we are responsible to submit and implement he detailed plan to comply the entire requirement mentioned in the annexure -2 with respect to Environmental, Social (including sexual exploitation and abuse (SEA) and gender-based violence (GBV)), Health and Safety risks. We also confirm that we have included all cost associated for implementation of this plan in our quotation.

We hereby confirm that this quotation is valid for 90 days as mentioned in Instructions to bidders.
We have not been currently debarred or suspended by any Government Organization, the World Bank Group.

Yours faithfully,

Authorized Signature : Date signed: _____

Name & Title of Signatory : _____
Name of Bidder : _____
Address : _____

BILL OF QUANTITIES

The approximate Bill of Quantities is indicated below to give an idea of the work which should be executed in accordance with the approved drawings and specifications to enable the bidder to furnish the Item rate wise price. Bidders may, however, note that no variations in the Item rate cost are acceptable (except where extra items are ordered by the Engineer).

A - BILL OF QUANTITY FOR STRUCTURAL & CIVIL WORKS

Sr No	Item	Unit	QUANTITY	Unit Rate in Rs. inclusive of all duties, GST, other levies etc.		TOTAL AMOUNT (Rs.)
				IN Figures	IN Words	
1.00	EARTH WORK					
1.10	EARTH WORK AND EXCAVATION					
	Notes:-					
1.1.1	Local Excavation: Excavation for individual footings/trenches etc. in the following strata measured from mass excavation level up to the required depth. Rate includes pumping/dewatering /sludge removal, back filling/disposing off the surplus earth to the local dumping yard at any time as directed by the Engineer-in-charge. The rate also includes supporting under ground utilities such cables, drains, service pipes water mains, if encountered. The soil proposed to be used for backfilling the excavated site should be free from any debris, boulders, pieces of broken foundation etc., approval by EIC. The measurement for earthwork shall be for the dimension of PCC / member forming the external face of the building at the lowest level multiplied by the depth of the excavation i.e. the difference between the initial level and final level as shown in the drawing or as directed.					
	0 M to 1.5 M	Cum	40			-
	1.5 M to 3.0 M	Cum	40			-
	Black Cotton Soil,Soft soil, sand and Murrum					-
1.1.3	Filling in plinth, raise formation and the area wherever required all depths elevation with selected excavated earth in layers not exceeding 150 mm thickness, including mixing, spreading, leveling, watering, ramming and consolidating each layer with power / hand roller of required capacity to obtain 97% modified proctor density as per relevant specification and dressing, leveling to the required profiles, etc. all complete as directed by the Engineer but excluding excavation.					
a)	With earth available within the site premises	Cum	27			-
b)	With earth brought from out side	Cum	301			-

Sr No	Item	Unit	QUANTITY	Unit Rate in Rs. inclusive of all duties, GST, other levies etc.		TOTAL AMOUNT (Rs.)-
				IN Figures	IN Words	
	Rubble selected and available from site premises as directed & approved by Engineer and obtained after breaking of stones/rubbles to the required size.					
a)	With rubble available at site	Cum	0			-
b)	With rubble brought from outside	Cum	6			-
1.1.6	Pest Control: Unless otherwise specified, the rates quoted for Anti-Termite treatment shall include the following :					
	Material Safety Data Sheet to be submitted and approved prior to use at site.					
a)	Providing and injecting chemical emulsion of approved manufacturer for Pre-construction Anti-termite treatment and creating a chemical barrier under and all around foundation/ column pits, back fill in immediate contact with foundation, wall trenches, basement excavation, junction of wall and floor, vertical fill around reinforced concrete walls of basement/ tanks and the top surface of plinth filling, external perimeter of the building, junction of pipes and conduits, etc. by treating at the rate of 5 litres of an emulsion concentrate of one percent concentration of CHLORPYRIFOC 20% EC ISI approved conforming (IS: 8944) (i.e. by diluting 5 litres of chlorpyrifoc 20% EC, with 95 litres of water) and spraying by high volume sprayer on one square metre surface area as per IS: 6313 (Parts II and III). Contractor shall give 10 years guarantee bond on court fee stamp paper of Rs. 100/-.	Sqm	251			-
	(Plinth area/ plan area of the building at ground floor only shall be measured for the payment under this item. Anti-termite treatment to other areas such as excavations, foundations, wall foundations, junctions, etc. shall be deemed to be included in the rate).					
SUB TOTAL OF EARTH WORK						-
2.00	CONCRETE WORKS					
2.10	PLAIN CEMENT CONCRETE					
	Note: For all plain concrete :					

Sr No	Item	Unit	QUANTITY	Unit Rate in Rs. inclusive of all duties, GST, other levies etc.		TOTAL AMOUNT (Rs.)-
				IN Figures	IN Words	
a)	Providing and laying in position plain cement concrete of M10 grade with 20mm downgraded coarse aggregate for leveling course/ fill under foundations, footings, basement rafts, steps, walls, platforms, ground floor, slabs on grade, sumps, manholes, and as plinth protection or as specified by Structural consultant / EIC etc., at any depth/ all levels, including centering, shuttering, scaffolding, vibrating, compacting, curing, removal of formwork, dewatering, all lead and lifts, in layers of specified thickness in alternative bays not exceeding 10 sqm etc. all complete and as directed for the following mixes. Without Vapour Barrier.	Cum	5			-
SUB TOTAL OF PLAIN CEMENT CONCRETE						-
2.20	REINFORCED CEMENT CONCRETE					
	Note: For all reinforced concrete :					
2.2.1	Providing and laying Cast in situ / Ready Mix cement concrete M-25 of trap / granite / quartzite / gneiss metal for R.C.C. work in foundations like raft , strip foundations , grill age and footing sof R.C.C. columns and steel stanchion etc.including bailing out water , Steel centering , formwork , coverblocks , laying / pumping , compaction and curing roughening the surface if special finish is to be provided (Excluding reinforcement and structural steel) etc. complete , with fully automatic microprocessor based PLC with SCADA enabled reversible DrumType mixer / concrete Batch mixplant (Panmixer) etc.complete. With fine aggregate (Crushed sand VSI Grade)					-
a)	Footing (M-25)	Cum	13			-
b)	Retaining Wall (M-25)	Cum				-
c)	Column (M-25)	Cum	6			-
d)	Plinth Beam (M-25)	Cum	9			-
f)	Slab (M-25)	Cum	0			-
2.30	Providing and laying in situ cement concrete M20 with TREMIX TREATMENT for 100 MM thickness for flooring with groove cutting of 4mm wide and 20 mm deep with necessary refilling with bitumen etc. complete.	Sq.M	251			-

Sr No	Item	Unit	QUANTITY	Unit Rate in Rs. inclusive of all duties, GST, other levies etc.		TOTAL AMOUNT (Rs.)-
				IN Figures	IN Words	
SUB TOTAL OF REINFORCED CEMENT CONCRETE						
3.00	STEEL WORKS					-
3.10	STEEL REINFORCEMENT					
	Basic Steel Rate:- Rs 63000/MT.					
	Note: This items may also be a free issue item by Employer.					
3.1.1	High yield strength deformed bars conforming to IS:1786 with Fe = 500 N/sq.mm	MT	3			-
3.20	Providing and fixing mild steel grill gate as per the detailed drawing including hinges, locking arrangements and painting in three coats of oil paint of approved colour and shade etc. complete.(weight 18 Kilogram. to 20 Kilogram. Per Sq.m.) Spec.One Number: As directed by Engineer- in-charge.	SQ.M	10.80			-
3.30	Structural Steel E-350 (TATA / JSW / Equivalent Make)					
	Supplying, fabricating, erecting and fixing in position of steel structures at all elevations using fusion welding quality steel E-350 (Fe490) conforming to IS:2062 - 2006. Rate shall include cost of cutting, welding, splice plates and packing plates, transporting, straightening, cleaning, fabricating and erecting in position welded/bolted Structural steelwork in columns, beams, trusses, purlins, platforms, ladders, monorails, staircases ,supports, strengthening of steel members etc. at site to line and level, supply of approved bolts/nuts/washers etc. complete as per drawings including painting as per G4/G5/G6 before erection and all materials and labour charges etc., complete and including Sand blasting & painted with 1 coats of enamel paint (Berger EPILUX SG – HHI 664002) of 35-50 micron each coat with air less spray gun over a coat of zinc chromate primer - 35-50 micron etc., complete as shown in drawings, as per specifications and as directed by the Engineer-in-Charge / Construction Manager. (The rate quoted shall include cost of bolts, nuts, washers, welding and electrodes required for the complete work).	MT	8.0			-
3.40	Structural Steel - Cold Formed Light gauged (Essar / TATA / JSW OR EQUIVALENT Make)					

Sr No	Item	Unit	QUANTITY	Unit Rate in Rs. inclusive of all duties, GST, other levies etc.		TOTAL AMOUNT (Rs.)-
				IN Figures	IN Words	
	Supplying, fabricating and erecting of Cold Formed Light Gauge structural steel members conforming to IS:801/ IS:811 hot-dip galvanised to IS:4759 - 96 including cutting, welding or bolting, splice plates and packing plates, transporting, straightening, cleaning, fabricating and erecting in position.	MT	2.3			-
3.50	Sheeting					
	PPGL 0.5 mm thk					
	Supply & Fixing of PPGI sheets of 0.5 mm thick as shown in drawing or as directed by engineer incharge with all necessary accessories.(Essar) Make)	MT	2.8			-
3.60	Roof Accessories					
	Supply & Fixing of 0.5 mm thk PPGL roof accessories as per drawing or as directed by engineer incharge-					
3.6.1	CORNER FLASHING	RMT	30			-
3.6.2	Center Ridge	RMT	15			-
3.6.3	Gable flashing	RMT	30			-
3.70	Roof Gutter					
	Roof Gutter (Assumed Girth- 600 mm) PPGI 0.5 mm Thk.					
	Supplying, fabricating and erecting in position PPGI Eaves Gutter of required size with stop ends,all fixing accessories, drop ends, etc., at all elevations levels & heights including aligning, leveling, providing and fixing bolts, nuts, washers etc., conforming to latest specification including straightening, cutting, welding, bending to shape, bolting etc., complete and as directed as per engineer incharge	RMT	60			-
3.80	Downtake Pipe					
	Providing and fixing of the rain water down take pipes of PPGI, the sectional area of rain water down take pipes provided shall be generally at the rate of 1 square cm per 70 to 80 square decimetre of roof area drained. No spout shall be less than 80 mm in diameter. The spacing of spouts shall be arranged to suit the position of openings in the wall including necessary accessories for fixing the pipe and including all materials and labour charges etc., complete as shown in drawings, as per specifications and as directed by the Engineer- in-Charge /	RMT	36			-
3.90	Polycarbonate Sheet					

Sr No	Item	Unit	QUANTITY	Unit Rate in Rs. inclusive of all duties, GST, other levies etc.		TOTAL AMOUNT (Rs.)-
				IN Figures	IN Words	
	Supply & Fixing of 2mm thk polycarbonate sheets as per drawing & as directed by engineer in-charge.	SQ.M	0			-
3.10	Turbo Ventilator					
	Supply & Fixing of turbo ventilator with 610 mm throat, having base ring & top plate in stainless steel of 0.8 mm thick, rotated using twin bearings of SKF - 600122 & 600322 permanently lubricated & sealed. Fixed in FRP base plate of 2mm thk clear 1.020 mtr wide & 1.7 mtr long.	NO.s	0			-
SUB TOTAL OF STEEL REINFORCEMENT						-
B CIVIL WORKS						
4	MASONRY					
4.10	Providing and constructing Solid Concrete Block masonry in proper line and level at all levels in cement mortar 1:6 / 1:4 (as mentioned in the item) using standard size of Blocks as 400 x 200mm of thickness as given below, with minimum compressive strength of each block not less than 5 N/Sq.mm including all scaffolding, staging, curing, all lifts, raking of joints, all labour, hire and fuel charges for all tools and plants employed etc. complete and as directed. Rate shall include providing Concrete Binders in proportion of M-20 concrete, 75mm thick reinforced with 2 nos. of 8 mm dia Fe 500 bars, RCC binders to be at every 1 metre interval from floor level. The rate to be inclusive of cost of reinforcement and formwork, cement mortar, cover blocks for reinforcement and all other incidental charges etc., all complete and as directed. The rate to also include closing the gap between the masonry and RCC beam / slab finished to required slope as directed by the Engineer-in-charge. Note:- The width of the joints not to exceed 10mm.					
a)	100mm thick block in cement mortar 1:4	Cu.m	0			-
b)	230mm thick block in cement mortar 1:6	Cu.m	58.328			-
TOTAL OF MASONARY WORKS						-
5	PLASTERING					

Sr No	Item	Unit	QUANTITY	Unit Rate in Rs. inclusive of all duties, GST, other levies etc.		TOTAL AMOUNT (Rs.)-	
				IN Figures	IN Words		
5.10	Providing and applying in one coat, 12mm thick Plaster on Internal surfaces of RCC/ brick/block walls in cement mortar 1:4, finished smooth with extra cement finishing, with cement not less than 2.2 kg per Sqm. Rate shall include for scaffolding, grooves, sills, pattas, curing, surface preparation before the application of plaster, providing PVC fibre mesh as mentioned in the notes above to a width of 150mm at the junctions of masonry and concrete works including tying in position by using suitable nails / clamps / screws and as directed etc. complete at all levels. The contractor shall make good the grooves, pockets etc. after the scaffolding is removed.	Sqm	190.2			-	
5.20	Providing and applying 25mm thick External Sand face Plaster in two coats for external surfaces of masonry, RCC. pergola, Chajja etc. with a base coat of 15mm thick in cement mortar 1:4 with the addition of water proofing compound of approved make and 100% virgin polypropylene fibres as mentioned in the notes above and finishing or final coat of 10mm thick in cement mortar 1:5 after roughening the surface of first coat in green condition with a wire brush and clearing of loose particles. The rate to be inclusive of sponge finish by taking out grains, all complete as per specification and as directed. The rate should also be inclusive of all scaffolding for single as well as double/multiple height areas, surface preparation, curing both the coats, sills, pattas, grooves, providing PVC fibre mesh as mentioned in the notes above to a width of 150mm at the junctions of masonry and concrete works including tying in position by using suitable nails / clamps / screws and as directed etc. complete at all levels.	Sqm	253.6			-	
TOTAL OF PLASTERING WORKS							-
6	PAINTING & FINISHING						
6.10	Providing and applying white-wash in two coats on old/newplaster do masonry surfaces and asbestos cement sheets including scaffolding and preparing the surface by brushing and brooming down etc. complete.	Sqm	190.2			-	

Sr No	Item	Unit	QUANTITY	Unit Rate in Rs. inclusive of all duties, GST, other levies etc.		TOTAL AMOUNT (Rs.)-
				IN Figures	IN Words	
6.20	Providing and applying colour-wash of approved colour and shade in two coats to news urface including scaffolding, brushing and brooming down (excluding base coat of white-wash) etc. complete.	Sqm	253.6			-
TOTAL OF PAINTING & FINISHING WORKS						-
7	ELECTRICAL WORKS					
7.1	Providing and fixing lioghtening conductor system comprising of erecting Air - Termination consisting of tubular copper rod of 25 mm dia.1.2 mm thick with multiple point shead 1.2mt.long (Heavy Duty)welded or clamped to G.I. pipe pole B grade 50 mm dia of required length with M.S . round base plate 25 Cm diamand 10 mm thick at bottom embeded in cement concrete 1:3:6 foundation of size 45 cm dia m x 45 cm Height and providing earthing with copper earth plate of size 60 x 60 x 0.3 cms with cad mium plate nut bolts to fix earthing strip burried in specially prepared earth pits 1.5 metre below ground level with 40 Kilogram charcoal and salt with altemate layers of charcoal and salt and G.I. pipe 40 mm dia2 meter length burried in earthing plate remining portion above ground level for watering and refilling comcpete Note-Copper strip from lightening conductor is not considered in this item.	Nos.	1			-
7.2	Providing and fixing copper strip 25 mm wide and 3 mm thick for lightening conductor including fixing with screws required scaffolding etc.complete Note- Lightening conductor and earthin pits is not considered in this item	Nos.	15			-
7.3	Supplying and errecting HMS PVC conduit FRLS Grade 25 mm dia. With pvc accessorieson wall/ ceilling as per specification No. WG-MA/ CON	M	50			-
7.4	Supplying and errecting mains with 1X1.5 sq. mm. FRLSH copper PVC insulated wire laid in provided conduit/trunking/inside pole/Buss bars or any other places as per specification No. WG-MA/CON	M	150			-
7.5	Supplying and errecting mains with 2X1.5 sq. mm. FRLSH copper PVC insulated wire laid in provided conduit/trunking/inside pole/Buss bars or any other places as per specification No. WG-MA/CON	M	150			-

Sr No	Item	Unit	QUANTITY	Unit Rate in Rs. inclusive of all duties, GST, other levies etc.		TOTAL AMOUNT (Rs.)-
				IN Figures	IN Words	
7.6	Supplying and erecting mains with 2X2.5 sq. mm. FRLSH copper PVC insulated wire laid in provided conduit/trunking/inside pole/Buss bars or any other places as per specification No. WG-MA/CON	M	15			-
7.7	Supplying and erecting modular type 3pin 6/16 A multy sockets with safety shutter, duly erected on provided plate and box with wiring connections complete	Nos	50			-
7.8	Supplying and erecting PVC surface maodular switch box with double mounting plate for 6 module duly erected	Nos	5			-
7.9	Supplying and erecting PVC surface maodular switch box with double mounting plate for 12 module duly erected	Nos	5			-
7.10	Supplying and erecting street light wall bracket made from 40 mm dia G I pipe 1.2 m in total length complete as per specification no FG-BKT/WB	Nos	5			-
7.11	Supplying, erecting and marking SPMCB 6A to 32 A, C series with rated short - circuit braking capacity 10kA in provided distribution board as per specification no SW-SWR/MCB	Nos	5			-
7.12	Providing earthing with galvnised iron earth plate size 60 X 60 C 0.6 cm complete with all materials, testing and recording the result as per specification no EA-Ep	Nos	2			-
TOTAL OF ELECTRICAL WORKS						-
8 ROAD WORKS						
8.10	Excavation for roadway in earth , soil of all sorts , sand, gravel or soft murum including dressing section to the required grade , camber and side slopes and conveying the excavated materials with all lifts up to a lead of 50m .and spreading for embankment or stacking as directed.	Cum	123.75			-
8.20	Providing earth work in embankment with approved materials obtained from other sources upto lead of 50m . including all lifts , laying in layers of 20cm. to 30cm .thickness breaking clods , dressing to the required lines , curves , grades & section , watering and compaction with vibratory roller with V -Satatt achment to achieve not less than 97% of standard proctor density etc. complete (Material obtained from Other sources)	Cum	123.75			-

Sr No	Item	Unit	QUANTITY	Unit Rate in Rs. inclusive of all duties, GST, other levies etc.		TOTAL AMOUNT (Rs.)-
				IN Figures	IN Words	
8.30	Supplying hard murum / kankar at the road site , including conveying and stacking complete.	Cum	123.75			-
8.40	Spreading hard murum/ soft murrum/ gravel or kankar for side width complete	Cum	123.75			-
8.50	Wateringandcompactingofembankmentformedofmaterialsobtainedfrom heroadcuttingwithinaleadof50m,notlessthan97%ofstandardProctordensit yafterlayingthem in layers of 20 cm. to 30 cm. with vibratory roller.	Cum	123.75			-
8.60	Compacting the hard murum side widths including laying in layers one ach side with vibratory roller including artificial watering etc. complete	Sq.m	412.50			-
TOTAL OF ROAD WORKS						-
9.0	LAB TESTING CHARGES					-
9.1	Cement - Fineness, Standard Consistency, Setting Time (Initial & Final), Compressive strength, Soundness	Nos	1.00			-
9.2	Concrete M-25 grade - Mix Design with all tests on basic materials	Nos	1.00			-
9.2	Concrete M-25 grade - Concrete cube compressive strength (Set of 3 Cubes)	Nos	4.00			-
9.3	Crushed metal - Water absorption, Specific gravity,Impact value,Crushing value	Nos	1.00			-
9.3	Brick - Crushing value, Water absorbaton, & Specific Gravity	Nos	1.00			-
9.4	Steel - Tensile strength ,Yield stress, ultimate tensile stress, %elongation, weight per running meter,Bend/Rebend test.(Set of 3 Bars)	Nos	1.00			-
9.4	Murum - Plasticity Index	Nos	1.00			-
9.5	Murum - Field Density of compacted layer	Nos	1.00			-
10.0	ROYALTY CHARGES					-
10.1	FOR SAND	CUM	13.36			-
10.2	FOR AGGREGATES / METAL	CUM	17.16			-
10.3	FOR MUROOM	CUM	548.94			-
10.4	FOR RUBBLE SOLLING	CUM	6.05			-

Sr No	Item	Unit	QUANTITY	Unit Rate in Rs. inclusive of all duties, GST, other levies etc.		TOTAL AMOUNT (Rs.)-
				IN Figures	IN Words	
11	Insurance	Lumsum	1			
12.00	Prviding and managing 20 Trees in the same premises, under Management Strategies And Implementation Plan (MSIP) to Manage Environmental , Social , Health And Safety.	Lumsum	22			-
Total Amount Inclusive of all in Rs.						

Note: The total amount mentioned in the form-8 should be same as mentioned in the BOQ.

We agree to execute the works in accordance with the terms and conditions mentioned in the invitation for quotation document , approved drawings and technical specifications at a total fixed contract price of Rs...../- (amount in figures) (Rs.only amount in words).

Signature

Name of Authorized Signatory.....

Bidder's Office Seal

Management Strategies and Implementation Plan (MSIP) to manage the Environmental, Social, Health and Safety (ESHS) risks and ESHS Code of Conduct

The policy goal, as a minimum, shall be to integrate environmental protection, forest and biodiversity conservation, pollution prevention, promote resource use efficiency, waste management, community health and safety measures and protection of cultural heritage sites during designing and execution of the civil works. It is also to promote gender equality, child protection, vulnerable people (including those with disabilities), sexual harassment, gender-based violence (GBV), sexual exploitation and abuse (SEA), HIV/AIDS awareness and prevention in the planning processes, programs, and various activities involved in the execution of the works.

The Bidder shall accordingly submit a comprehensive and concise Management Strategies and Implementation Plan (MSIP) to manage the Environmental, Social (including sexual exploitation and abuse (SEA) and gender-based violence (GBV), Health and Safety (ESHS) risks, and ESHS Code of Conduct.

The Plan shall include;

1. Management of construction debris (silt, oil, solid waste, wastewater, etc.) and traffic management plan to ensure safety of local communities and ecosystem from construction activities
2. Abatement plan for environmental pollution, re-vegetation of construction site and sensitization of workforce
3. Water resource protection plan to prevent contamination of drinking water;
4. Boundary marking and protection strategy to prevent depositing on private land and offsite adverse impacts;
5. Gender based violence and sexual exploitation and abuse (GBV/SEA) prevention and response action plan
6. Mobilization strategy
7. Worker's camp management plan including the process for mitigating construction related impacts on local community
8. Occupational health and safety plan of the workforce
9. Child Protection Plan
10. Capacity building/training Plan
11. HIV/AIDS awareness and prevention plan
12. Prevention and mitigation plan of COVID-19

The plan shall describe the actions, materials, equipment, management processes, including costs etc. that will be implemented by the Contractor, and its subcontractors.

The Bidder shall document and submit the Code of Conduct that will apply to its employees and subcontractors, to mitigate ESHS risks and to ensure compliance with its Environmental, Social, Health and Safety (ESHS) obligations under the contract.

In addition, the Bidder shall submit an outline of how this Code of Conduct will be implemented and availability of qualified and trained personnel to supervise and implement the action plan. This will include how it will be introduced into conditions of employment/engagement, what training will be provided, how it will be monitored and how the Contractor proposes to deal with any breaches.

For details, please refer to the chapter no. 11 on the Construction Management Guideline and chapter no 14 on Labour Management Framework of the SMART project's Environment & Social Management Framework (ESMF) report. For accessing ESMF report,

please visit https://www.smart-mh.org/cdn//2019/08/190818171526_405e4be8b9d3ce2374fe29ce1561a62b.pdf and for EHS guideline visit **Error! Hyperlink reference not valid.**

**LETTER OF ACCEPTANCE
CUM NOTICE TO PROCEED WITH THE WORK
(LETTER HEAD OF THE EMPLOYER)**

Dated: _____

To: _____ [Name and address of the Contractor]

Dear Sirs,

This is to notify you that your quotation dated _____ for execution of the _____ for the contract price of Rupees _____ [amount in words and figures], is hereby accepted by us.

You are hereby requested to furnish performance security for an amount of Rs. _____ (equivalent to 3% of the contract price) within 15 days of the receipt of the letter. The Performance Security in the form of Bank guarantee or a Bank draft in favour of..... (Employer) shall be valid until date 28 days after the date of issue of the Certificate of Completion i.e., up to _____. Failure to furnish the Performance Security will entail cancellation of the award of contract.

You have to submit detailed ESHS compliance plan within one week from the date of this letter of acceptance. Failure to submit the acceptable ESHS plan will entail cancellation of the award of contract.

You are also requested to sign the agreement form and proceed with the work not later than _____ under the instructions of the Engineer, _____ and ensure its completion within the contract period.

With the issuance of this acceptance letter and you're furnishing the Performance Security, contract for the above said work stands concluded.

Yours faithfully,

**Authorized Signature
Name and title of Signatory**

**Draft Agreement form for
ARTICLES OF AGREEMENT**

1. This deed of agreement is made in the form of agreement on _____ day _____ month _____ 20 __, between the _____ (Employer) or his authorized representative (hereinafter referred to as the first party) and _____ (Name of the Contractor), S/O _____ resident of _____¹ (hereinafter referred to as the second party), to execute the work of construction of _____ (hereinafter referred to as works) on the following terms and conditions.

2. Cost of the Contract

The total cost of the works (hereinafter referred to as the “total cost”) is Rs./- as per the final contract amount /amount reflected in final BOQ.

3. Payments under the contract:

Payments to the second party for the construction work will be released by the first party in the following manner: -

1 st R. A. Bill	25% of the total cost
2 nd R. A. Bill	20% of the total cost
3 rd R. A. Bill	20% of the total cost
4 th R. A. Bill	20% of the total cost
Final Work Completed as per Tender	15% of the total cost

3.1 (Not Applicable)

3.1 The Employer shall retain (Retention Money) 6% of the amount from each payment due to the Contractor subject to the maximum of 5% of final contract price. Half of the amount retained shall be repaid upon completion of the works, and other half shall be repaid when the Defects Liability Period has passed and the Engineer has certified that all Defects notified to the Contractor before the end of this period have been corrected. On completion of the whole works the Contractor may substitute the balance retention money with an “on demand” Bank guarantee.

3.3 Payments at each stage will be made by the first party:

- (a) on the second party submitting an invoice for an equivalent amount;
- (b) on certification of the invoice (except for the first installment) by the engineer nominated by the first party with respect to quality of works in the format in Annexure - 1; and
- (c) upon proper and justified utilization of at least 50 % of the previous installment and 100 % of any prior installment.

4. Notice by Contractor to Engineer

The second party, on the works reaching each stage of construction, shall issue a notice to the first party or the Engineer nominated by the first party [who is

¹In case of a firm insert ‘complete address of the firm’. In case of an individual contractor insert identification like ‘son of and resident of’ etc.

responsible for supervising the contractor, administering the contract, certifying payments due to the contractor, issuing and valuing variations to the contract, awarding extension of time etc.] to visit the site for certification of stage completion. Within 15 days of the receipt of such notice, the first party or the engineer nominated by it, will ensure issue of stage completion certificate after due verification.

5. Completion time

The works should be completed in **11 Months** from the date of this Agreement. In exceptional circumstances, the time period stated in this clause may be extended in writing by mutual consent of both the parties.

6. If any of the compensation events mentioned below would prevent the work being completed by the intended completion date, the first party will decide on the intended completion date being extended by a suitable period:

- a) The first party does not give access to the site or a part thereof by the agreed period.
- b) The first party orders a delay or does not issue completed drawings, specifications or instructions for execution of the work on time.
- c) Ground conditions are substantially more adverse than could reasonably have been assumed before issue of letter of acceptance and from information provided to second party or from visual inspection of the site.
- d) Payments due to the second party are delayed without reason.
- e) Certification for stage completion of the work is delayed unreasonably.

7. Any willful delay on the part of the second party in completing the construction within the stipulated period will render him liable to pay liquidated damages. @ 0.05 % of the contract value of the work per day which will be deducted from payments due to him. The first party may cancel the contract and take recourse to such other action as deemed appropriate once the total amount of liquidated damages exceeds 5 % of the contract amount.

8. Duties and responsibilities of the first party

8.1 The first party shall be responsible for providing regular and frequent supervision and guidance to the second party for carrying out the works as per specifications. This will include written guidelines and regular site visit of the authorized personnel of the first party, for checking quality of material and construction to ensure that it is as per the norms.

8.2 The first party shall supply 3 sets of drawings, specifications and guidelines to the second party for the proposed works.

8.3 Possession of the site will be handed over to the second party within 10 days of signing of the agreement.

8.4 The Engineer or such other person as may be authorized by the first party shall hold meeting once in a month where the second party or his representative at site will submit the latest information including progress report and difficulties if any, in the execution of the work. The whole team may jointly inspect the site on a particular day to take stock of activities.

8.5 The Engineer shall record his observations/instructions at the time of his site visit in a site register maintained by the second party. The second party will carry out the instructions and promptly rectify any deviations pointed out by the engineer. If the deviations are not rectified, within the time specified in the Engineer's notice, the first party as well as the engineer nominated by it, may instruct stoppage or suspension of the construction. It shall thereupon be open to the first party or the engineer to have the deviations rectified at the cost of the second party.

8.6 The Engineer shall issue a Certificate of Completion of the Works on the request of the second party, and upon deciding that the whole of the Works is completed.

9. Duties and responsibilities of the second party

9.1 The second party shall:

- a) take up the works and arrange for its completion within the time period stipulated in clause 5;
- b) employ suitable skilled persons to carry out the works;
- c) regularly supervise and monitor the progress of work;
- d) abide by the technical suggestions/ direction of supervisory personnel including engineers etc. regarding building construction;
- e) be responsible for bringing any discrepancy to the notice of the representative of the first party and seek necessary clarification;
- f) ensure that the work is carried out in accordance with specifications, drawings and within the total of the contract amount without any cost escalation;
- g) keep the first party informed about the progress of work;
- h) correct the notified defects within the length of time specified by the Engineer;
- i) be responsible for all security and watch and ward arrangements at site till handing over of the works to the first party;
- j) maintain necessary insurance against loss of materials/cash, etc. or workman disability compensation claims of the personnel deployed on the works as well as third party claims from the start date to the end of defect liability period;
- k) pay all duties, taxes and other levies payable by construction agencies as per law under the contract (First party will effect deduction from running bills in respect of such taxes as may be imposed under the law);
- l) abide by the regulatory authority conditions (if any) attached to any permits or approvals for the project; and the ESHS Management Strategies and Implementation Plan and ESHS Code of Conduct, if any prescribed by the Employer;
- m) abide by all labour enactments and rules made there under, regulations, notifications and bye laws of the State or Central Government or local authorities;
- n) abide by all enactments on environmental protection and rules made there under, regulations, notifications and by-laws of the State or Central Government, or local authorities;
- o) be responsible for the safety of all activities on the Site.

10. Variations / Extra Items

The works shall be executed by the second party in accordance with the approved drawings and specifications. No variation in cost is acceptable. However, if the Engineer issues instructions for execution of extra items, the following procedure shall be followed:-

- a) The second party shall provide the Engineer with a quotation for carrying out the extra items when requested to do so by the Engineer. The Engineer shall assess the quotation, which shall be given within seven days of the request before the extra items are ordered.

- b) If the quotation given by the second party is unreasonable, the Engineer may order the extra items and make a change to the Contract Price which shall be based on Engineer's own forecast of the effects of the extra items on the Contractor's costs.
- c) The second party shall not be entitled to additional payment for costs, which could have been avoided by giving early warning.

11. Securities

The Performance Security shall be provided to the Employer no later than the date specified in the Letter of Acceptance and shall be issued in an amount and form and by a bank acceptable to the Employer. The Performance Security shall be valid until a date 28 days from the date of issue of the Certificate of Completion in the case of a Bank Guarantee.

12. Termination

12.1 The Employer may terminate the Contract if the other party causes a fundamental breach of the Contract.

12.2 Fundamental breaches of Contract include, but shall not be limited to the following:

- (a) the contractor stops work for 28 days and the stoppage has not been authorized by the Engineer;
- (b) the Contractor has become bankrupt or goes into liquidation other than for a reconstruction or amalgamation;
- (c) the Engineer gives Notice that failure to correct a particular Defect is a fundamental breach of Contract and the Contractor fails to correct it within a reasonable period of time determined by the Engineer;
- (d) the Contractor does not maintain a security which is required;
- (e) the Contractor has engaged in Fraud and Corruption as defined in Section C, in competing for or in executing the Contract; and
- (f) the contractor has delayed the completion of the Works by the number of days for which the maximum amount of liquidated damages can be paid

12.3 Notwithstanding the above, the Employer may terminate the Contract for convenience.

12.4 If the Contract is terminated the Contractor shall stop work immediately, make the Site safe and secure and leave the Site as soon as reasonably possible.

13. Payment upon Termination

13.1 If the Contract is terminated because of a fundamental breach of Contract by the Contractor, the Engineer shall issue a certificate for the value of the work done less advance payments received up to the date of the issue of the certificate, less other recoveries due in terms of the contract, less taxes due to be deducted at source as per applicable law.

13.2 If the Contract is terminated at the Employer's convenience, the Engineer shall issue a certificate for the value of the work done, the reasonable cost of removal of Equipment, repatriation of the Contractor's personnel employed solely on the Works, and the Contractor's costs of protecting and securing the Works and less advance payments received up to the date of the certificate, less other recoveries due in terms of the contract and less taxes due to be deducted at source as per applicable law.

14. Dispute settlement

If over the works, any dispute arises between the two parties, relating to any aspects of this Agreement, the parties shall first attempt to settle the dispute through mutual and amicable consultation.

In the event of agreement not being reached, the matter will be referred for arbitration by a Sole Arbitrator not below the level of retired Chief Engineer / Superintending Engineer, (not connected in part or whole with this Project in his service) to be appointed by the first party. The Arbitration will be conducted in accordance with the Arbitration and Conciliation Act, 1996. The decision of the Arbitrator shall be final and binding on both the parties.

15. Fraud and Corruption

The World Bank requires compliance with the Bank's Anti-Corruption Guidelines and its prevailing sanctions policies and procedures as set forth in the WBG's Sanctions Framework, as set forth in Section C. In further pursuance of this policy, the Contractor shall permit and shall cause its sub-contractors, sub-consultants, service providers, suppliers, agents' personnel, to permit the Bank to inspect all accounts, records, and other documents relating to the procurement process, selection and/or contract execution, and to have them audited by auditors appointed by the Bank.

16. Approved rates: As per the attached annexure

Annexure I

Format of certificate

Certified that the works up to ----- level in respect of construction of ----- at ----- have been executed in accordance with the approved drawings and technical specifications.

Signature
Name & Designation
(Official address)

Place:
Date:

Office seal

Annexure-2

ESHS Compliance Plan

After finalization of a contractor, it is mandatory for the contractor to prepare and implement the Environment and Social Management Plan (ESMP). For Health and Safety of workers and community, the plan entailing the below aspects need to be prepared and implemented;

A) Social Management Plan:

1. **In case of labour influx**, (if labours are not available locally and to be outsourced from outside district/region/state) the basic residence facility (setting up of camps, provision of residence with all basic amenities) need to be provided. Due to labour influx, there may be risk of communicable disease, gender based violence among workers and community. Hence the plan to avoid/mitigate these factors also need to be prepared and implemented.
2. **At workplace** : The following provisions/measures need to be complied at workplace
 - The provision of clean drinking water, health and hygiene facilities, separate washrooms for male & female, first aid kit, child crèches for women etc.
 - Mechanism to restrict sexual harassment of women and child at construction site, mechanism to prevent child labour and bonded labour, etc.
 - For safety of workers, Safety equipment like provision of personal protection equipment (PPE) for workers, such as safety boots, helmets, masks, gloves, protective clothing, goggles, full-face eye shields, and ear protection, firefighting equipment need to be provided.
3. **Community Safety Measure:** For avoiding the accidents due to increase in traffic at local level, the plan regarding road transport and road traffic management i.e. to provide signs at strategic locations of the roads, install and maintain a display board at each important road intersection on the roads to be used during construction, display boards about information regarding construction works as well as vehicle movements and warning signs etc.. needs to be prepared and implemented.

B) Environmental Management Plan

I. Air Quality

Possible impacts during construction are dust emission due to activities such as excavation, leveling, movement of vehicles at construction site. Emission due to operation of construction machineries.

Following mitigation measures should be adopted by the contractors;

- 1) Construction materials shall be transported to the site in covered trucks, where necessary.
- 2) Land clearing for construction site will be kept at the absolute minimum practicable.
- 3) Layout should be designed to minimize the removal of soil and vegetation

- 4) Topsoil removed will be preserved for later reinstatement purposes by piling it within and along the boundary of the site.
- 5) Dust suppression systems (water spray) shall be put into service as per requirement at the construction site.
- 6) Fuel used for machineries shall be clean and with low Sulphur content.
- 7) Construction machineries used shall have a valid PUC certificate.
- 8) Construction workers shall be provided with clean fuel for cooking.
- 9) Reducing speed of vehicle on Water Bound Macadam (WBM) road within the construction site to 20 km/hr will reduce dust emission.
- 10) Vehicles used shall be Bharat Stage V or VI compliant as per the prevailing regulations.

II. Noise quality

Noise quality shall be impacted due to operation of construction machineries. Mitigation measures should be adopted are as follows;

- 1) Provision of silencers to modulate the noise generated by machines
- 2) Provision of protective devices like ear muff/ plugs to the workers who will be working in the noise prone areas.
- 3) Acoustic enclosure to D.G set shall be provided if used.
- 4) Construction activity generating noise shall be limited to the day time

III. Water Use and Quality

Following water conservation measures should be adopted;

- 1) Curing water shall be sprayed on to the concrete structures instead of free flow of water.
- 2) Concrete structures shall be covered with thick cloth/gunny bags to avoid water rebound and will ensure sustained and complete curing.
- 3) Following mitigation measures should be integrated in case of waste water generated from temporary labour tents or rainwater run-off from construction sites;
- 4) Sewage generated shall be treated in septic tank followed by soak pits.
- 5) Silt traps shall be provided prior to discharge of run-off from construction area into drains.
- 6) An oil trap shall be provided in the drainage line to prevent contamination by accidental spillage of oil and grease.
- 7) Washdown area shall be provided for cleaning of vehicle wheels and the waste water shall be drained properly. Here also a settling pit and baffled oil water separator shall be provided.

IV. Soil Quality

Possible impacts on Soil Quality are due to generation of construction waste and municipal solid waste from workers camps.

Following mitigation measures should be followed;

- 1) Construction waste generated shall be collected, segregated and disposed as per the Construction and Demolition Waste Rules 2016.
- 2) Municipal solid waste generated shall be disposed as per Solid Waste Management Rules 2016.

- 3) Used oil generated shall be collected and sold to authorized recyclers.

V. Design Elements for energy efficiency:

General measures that shall be adopted in the design for energy efficient and sustainable design of building for Warehouse, Cold Storages, etc. are as follows;

- 1) Building design shall utilize maximum natural daylight and rely minimum on artificial lighting.
- 2) Use low energy Light Emitting Diode (LED) lighting system to reduce their energy usage.
- 3) Waste management based on the concept of reduce, reuse and recycle shall be adopted to promote waste avoidance ahead of recycling and disposal.
- 4) Electrical / electronic equipment used in the facility shall be of 3 star and above rating.
- 5) Warehouse and Retails shall utilize solar energy for internal and external lighting to the extent possible.
- 6) Construction material to the extent possible shall be sourced locally to reduce carbon foot print.
- 7) Building material to the extent possible considering the design requirement shall utilize recyclable material such as fly ash bricks.
- 8) Refrigerator trucks shall be energy efficient and Bharat Stage VI and above compliant as per the prevailing norms.
- 9) Cold Storages and Retails shall use refrigerants that are environment friendly and non-ozone depleting and adhere to Ozone Depleting Substances (Regulation and Control) Rules, 2000 and its amendments.
- 10) HVAC (Heat Ventilation and Air Conditioning) system used shall be energy efficient.

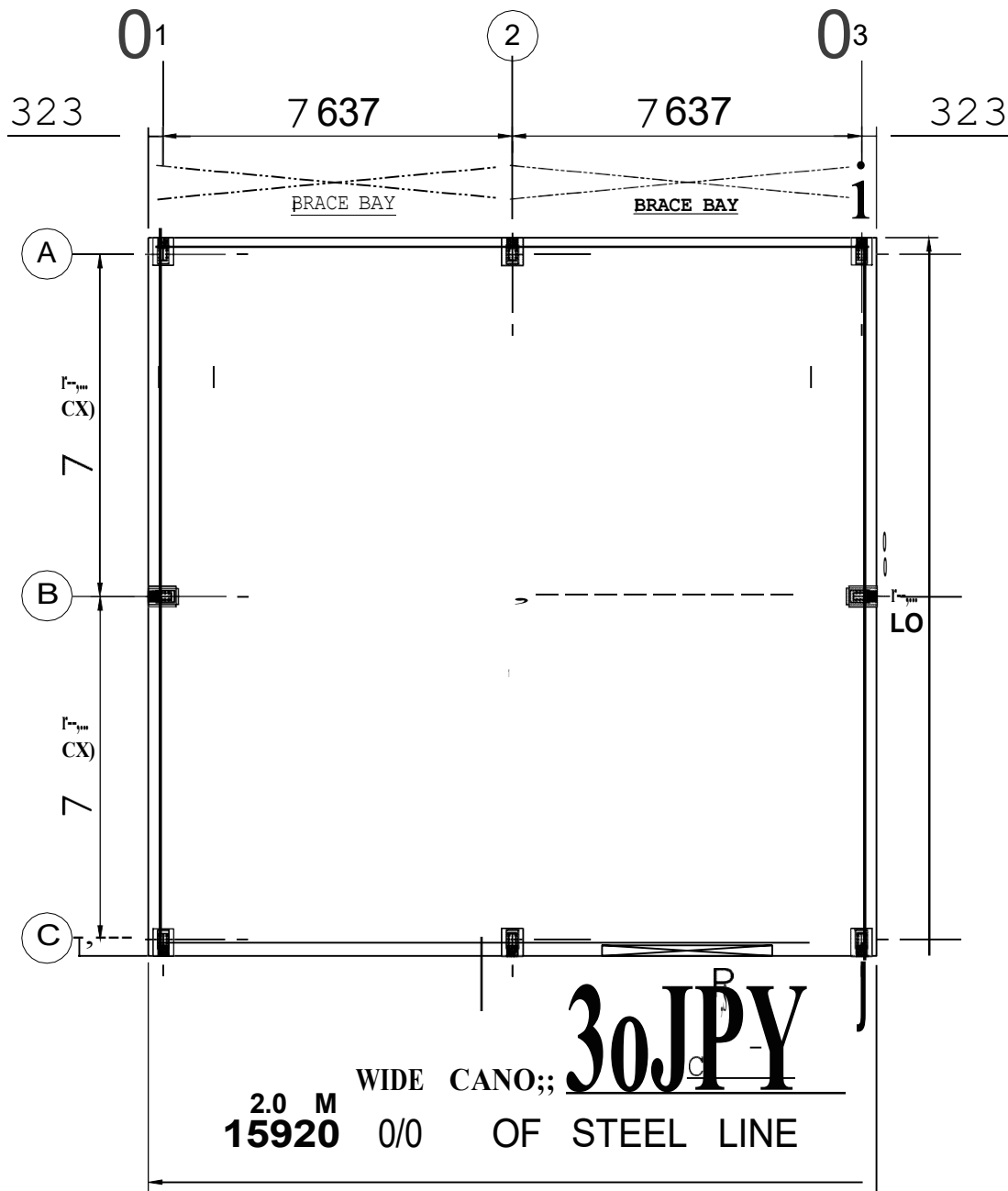

- NOTES
1. THIS DRAWING IS TO BE READ IN CONJUNCTION WITH ALL OTHER RELEVANT ARCHITECTURAL SPECIFICATIONS.
 2. ALL DIMENSIONS ARE IN MILLIMETERS UNLESS OTHERWISE SPECIFIED.
 3. DO NOT SCALE THE DRAWING.
 4. ALL WORK SHALL BE IN ACCORDANCE WITH THE SPECIFICATIONS OF THE BUREAU OF STANDARDS OF INDIA (B.S.) UNLESS OTHERWISE SPECIFIED.
 5. ALL MATERIALS SHALL BE OF THE BEST QUALITY AND SHALL BE AS PER THE SPECIFICATIONS OF THE BUREAU OF STANDARDS OF INDIA (B.S.) UNLESS OTHERWISE SPECIFIED.
 6. ALL WORK SHALL BE IN ACCORDANCE WITH THE SPECIFICATIONS OF THE BUREAU OF STANDARDS OF INDIA (B.S.) UNLESS OTHERWISE SPECIFIED.
 7. ALL WORK SHALL BE IN ACCORDANCE WITH THE SPECIFICATIONS OF THE BUREAU OF STANDARDS OF INDIA (B.S.) UNLESS OTHERWISE SPECIFIED.
 8. ALL WORK SHALL BE IN ACCORDANCE WITH THE SPECIFICATIONS OF THE BUREAU OF STANDARDS OF INDIA (B.S.) UNLESS OTHERWISE SPECIFIED.
 9. PERMITTING AND ALL OTHER TERMS AS PER CONTRACTS.

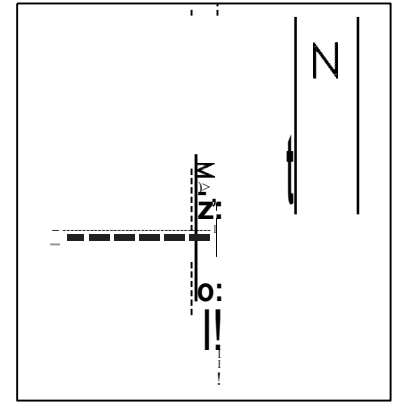

KEY PLAN

2.0 M WIDE CANO;;
15920 OF STEEL LINE
30JPY

LAYOUT PLAN

TENDER DRAWING		DRAWING TITLE :- LAYOUT PLAN (MACHINE SHADE)	
PROJECT :- PROPOSED PEB SHED FOR MANDHAL AGRO PRODUCT FARMERS PRODUCER COMPANY LIMITED, DIST- NAGPUR	DRAWING NUMBER 23/SP/SMART-01/NGP/TRO/1/W	SERIAL NUMBER 1	REV NO. :- RO
DESIGN BY :- A.L.	DRAWN BY :- VJB	CHECKED BY :- NAGESH	SCALE :- NTS
STRUCTURAL CONSULTANT :- A&A ASSOCIATES, NANDED. ABHAY O LOKMANWAR M.E.STRUCTURAL	CHECKED BY :- NAGESH	DATE :- 28/05/23	APPROVED BY :- A.L.

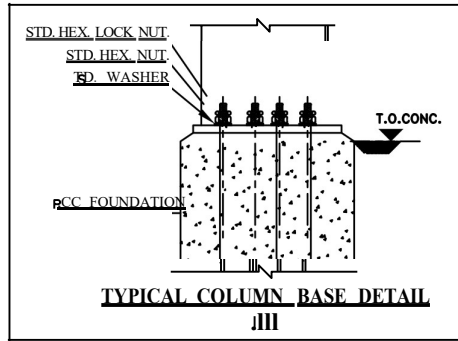
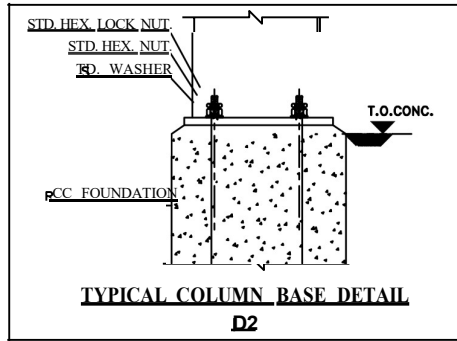
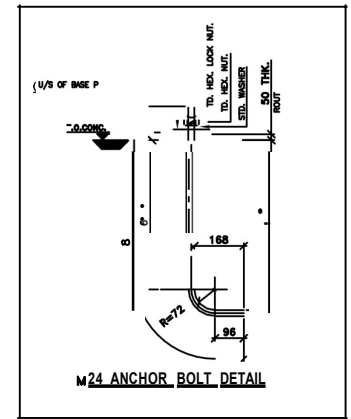
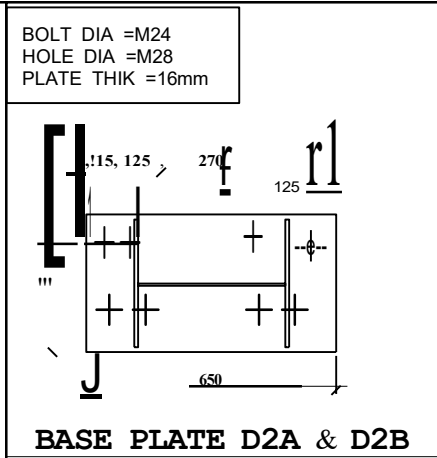
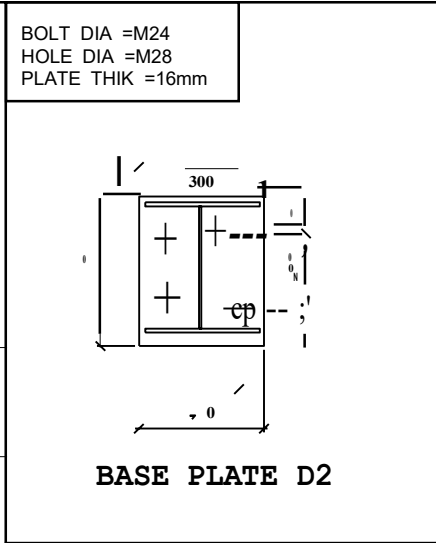
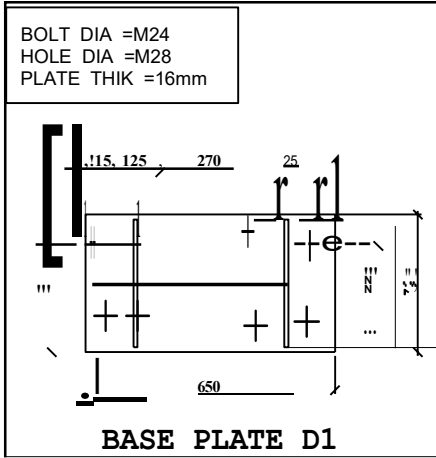

NOTES

1. THIS DRAWING IS TO BE READ IN CONJUNCTION WITH ALL OTHER RELEVANT ARCHITECTURAL AND STRUCTURAL DRAWINGS.
2. ALL DIMENSIONS ARE IN MILLIMETERS UNLESS NOTED OTHERWISE.
3. DO NOT SCALE THE DRAWING.
4. ALL HOLLOW JOBS SHALL BE OF GRADE Y.S. 345 N. 10025-5275 OR EQUIVALENT.
5. ALL THE BOLT JOBS SHALL BE OF GRADE Y.S. 345 N. 10025-5275 OR EQUIVALENT.
6. ALL DIMENSIONS ARE AS STAN-ARD UNLESS OTHERWISE NOTED.
7. BOLTS FOR MAIN STRUCTURE ARE AS PER IS 4321.
8. BOLTS FOR BRACINGS, PURLS, GIRTS ETC. ARE GRADE 46.
9. PAINTING SYSTEM AND ALL OTHER TERMS AS PER CONTRACT.

TENDER DRAWING		DRAWING TITLE :- FOUNDATION BOLT DETAILS(MACHINE SHADE)	
PROJECT :-	PROPOSED PEB SHED FOR MANDHAL AGRO PRODUCT FARMERS PRODUCER COMPANY LIMITED, DIST- NAGPUR	DRAWING NUMBER	23/SP/SMART-01/NGP/TROI/W
DESIGN BY :-	A.L.	SERIAL NUMBER	2
DRAWN BY :-	VJB	REV NO.:-	RO
CHECKED BY :-	NAGESH	SCALE :-	NTS
APPROVED BY :-	A.L.	DATE :-	28/05/23
STRUCTURAL CONSULTANT :-	A&A ASSOCIATES, NANDED, ABHAY O LOKMANWAR, M.E.STRUCTURAL		

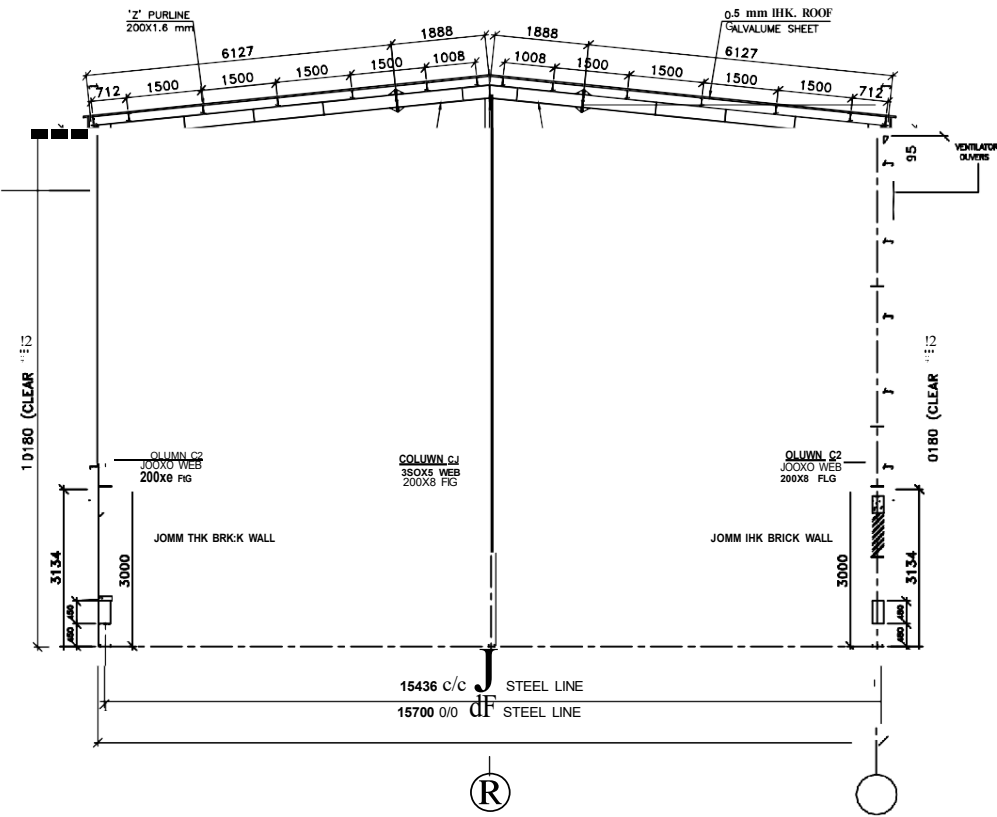

PORTAL FRAME AT GRID 1 & 3.

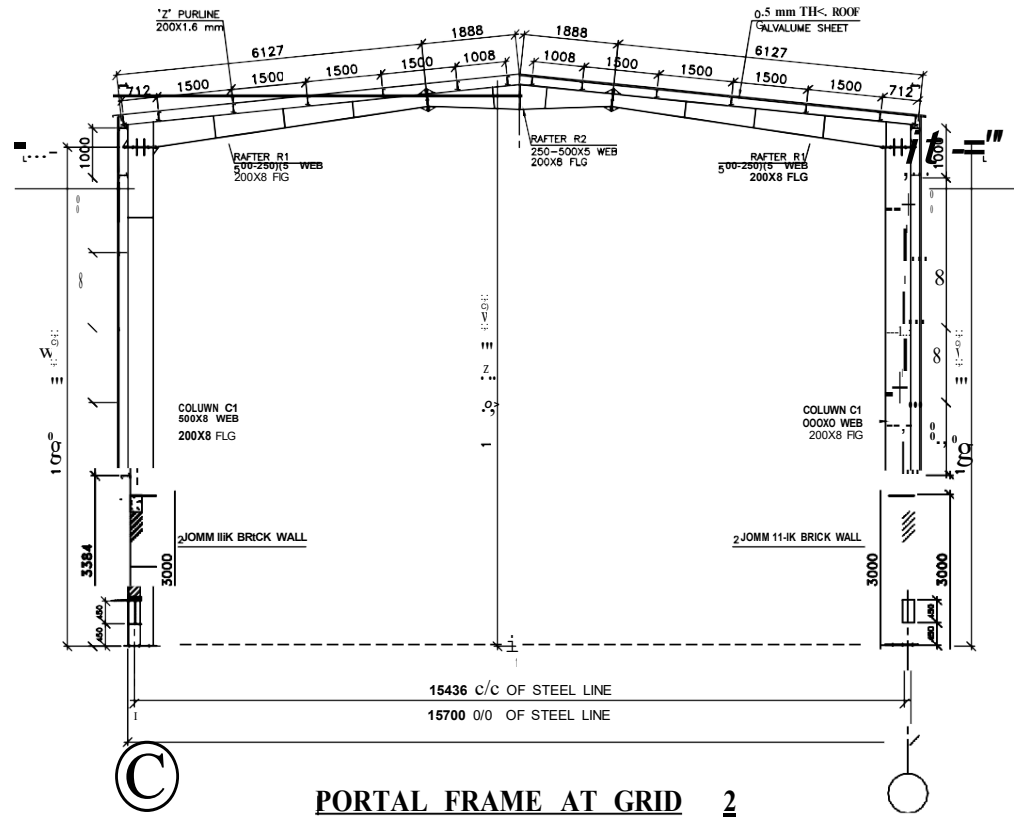

PORTAL FRAME AT GRID 2

NOTES

1. THIS DRAWING IS TO BE READ IN CONJUNCTION WITH ALL OTHER RELEVANT ARCHITECTURAL AND STRUCTURAL DRAWINGS.
2. ALL DIMENSIONS ARE IN MILLIMETERS UNLESS NOTED OTHERWISE.
3. DO NOT SCALE THE DRAWING.
4. ALL HOT ROLLED JOBS ARE SNAU, COFORII 10 BSEN 10025-S275 OR EQUIVALENT OF GRADE Y.S. 345 N.
5. ALL THE BUILT UP JOBS ARE SNAU, COFORII 10 ASIII Mn OR BSEN 10025-S355.
6. ALL WELDS ARE AWS STANDARD UNLESS OTHERWISE NOTED.
7. BOLTS FOR MAIN STRUCTURAL CONNECTIONS ARE ASIII A25.
8. BOLTS FOR BRACINGS, PURLINS, GIRTS ETC. ARE GRADE 46.
9. PAINTING SYSTEM AND ALL OTHER TERMS AS PER CONTRACT.

TENDER DRAWING		DRAWING TITLE :- PORTAL FRAME DETAILS (MACHINE SHADE)	
PROJECT :-	PROPOSED PEB SHED FOR MANDHAL AGRO PRODUCT FARMERS PRODUCER COMPANY LIMITED. DIST- NAGPUR	DRAWING NUMBER 23/SP/SMART-01/NGP/ITROI/W	SERIAL NUMBER 3
DESIGNED BY :-	A.L.	DESIGNED BY :-	REV NO. :- RO
DRAWN BY :-	VJB	DRAWN BY :-	SCALE :- NTS
STRUCTURAL CONSULTANT :- A&A ASSOCIATES, NAGPUR. ABHAY O LOKMANWAR M.E.STRUCTURAL	CHECKED BY :- NAGESH	DATE :-	28/05/23
	APPROVED BY :- A.L.		

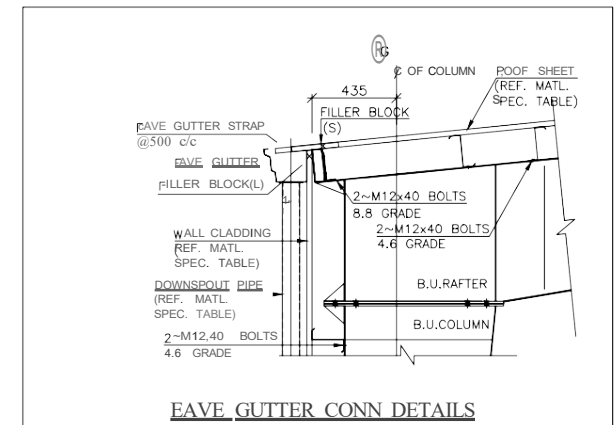
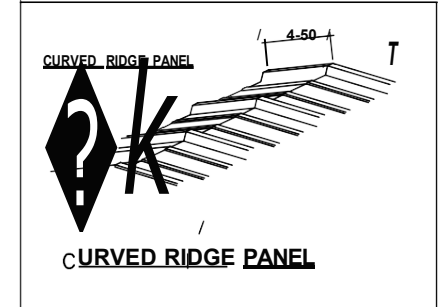
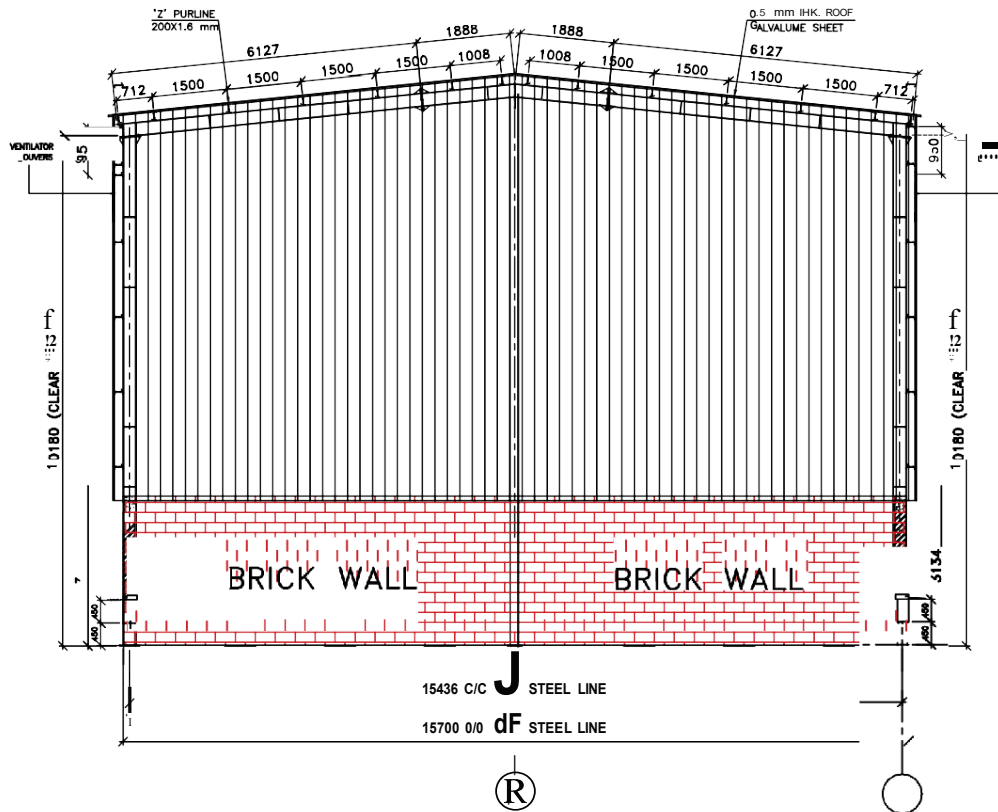
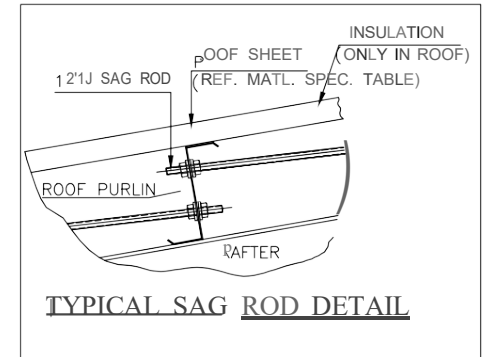
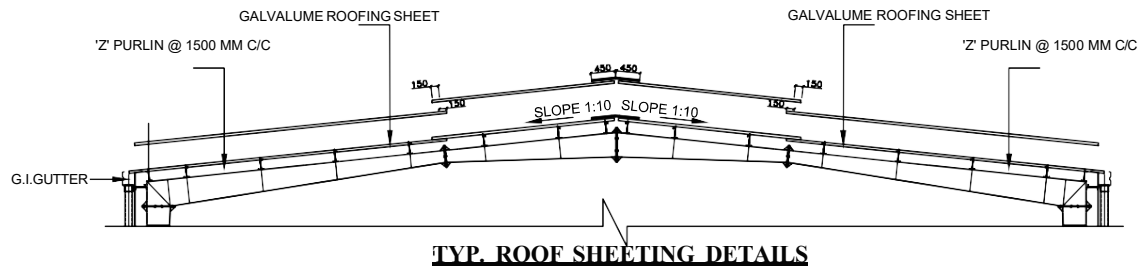

NOTES

1. THIS DRAWING IS TO BE READ IN CONNECTION WITH THE SPECIFICATIONS AND CONDITIONS OF CONTRACT.
2. ALL DIMENSIONS ARE IN METERS UNLESS OTHERWISE NOTED.
3. DO NOT SCALE THIS DRAWING.
4. ALL HOT ROLLED JOBS SHAU, COFORM 10 BSEN 10025-5275 OR EQUIVALENT OF GRADE Y.S.345 N- OR BSEN 10025-5355
5. ALL THE BOLT JOBS SHAU, COFORM 10 AS III Mn OR BSEN 10025-5355
6. ALL JOBS ARE AS STANDARD UNLESS OTHERWISE NOTED.
7. BOLTS FOR MAIN STRUCTURAL CONNECTIONS ARE AS III A321
8. BOLTS FOR BRACINGS, PURLINS, GIRTS ETC. ARE GRADE 46
9. PAINTING SYSTEM AND ALL OTHER TERMS AS PER CONTRACTS.

TENDER DRAWING		DRAWING TITLE:- SHEETING DETAILS (MACHINE SHADE)	
PROJECT:-	PROPOSED PEB SHED FOR MANDHAL AGRO PRODUCT FARMERS PRODUCER COMPANY LIMITED, DIST- NAGPUR	DRAWING NUMBER	23/SP/SMART-01/NGP/TROI/W
DESIGN BY:-	A.L.	SERIAL NUMBER	4
DRAWN BY:-	VJB	REV NO:-	RO
STRUCTURAL CONSULTANT:-	A&A ASSOCIATES, NANGED, ABHAY O LOKMANWAR M.E.STRUCTURAL	SCALE:-	NTS
CHECKED BY:-	NAGESH	DATE:-	28/05/23
APPROVED BY:-	A.L.		

NOTES

1. THIS DRAWING IS TO BE READ IN CONJUNCTION WITH ALL OTHER RELEVANT ARCHITECTURAL AND STRUCTURAL DRAWINGS.
2. ALL DIMENSIONS ARE IN MILLIMETERS AND LEVELS ARE IN METERS UNLESS NOTED OTHERWISE.
3. DO NOT SCALE THE DRAWING.
4. ALL HOT ROLLED MEMBERS SHALL CONFORM TO BSEN 10025-S275 OR EQUIVALENT & OF GRADE Y.S. 345 N/SQMM
5. ALL THE BUILT UP MEMBERS SHALL CONFORM TO ASTM A572 OR BSEN 10025-S355
6. ALL WELDS ARE AWS STANDARD UNLESS OTHERWISE NOTED.
7. BOLTS FOR MAIN STRUCTURAL CONNECTIONS ARE ASTM A325
8. BOLTS FOR BRACINGS, PURLINS, GIRTS ETC. ARE GRADE 4.6
9. PAINTING SYSTEM AND ALL OTHER TERMS AS PER CONTRACTS.

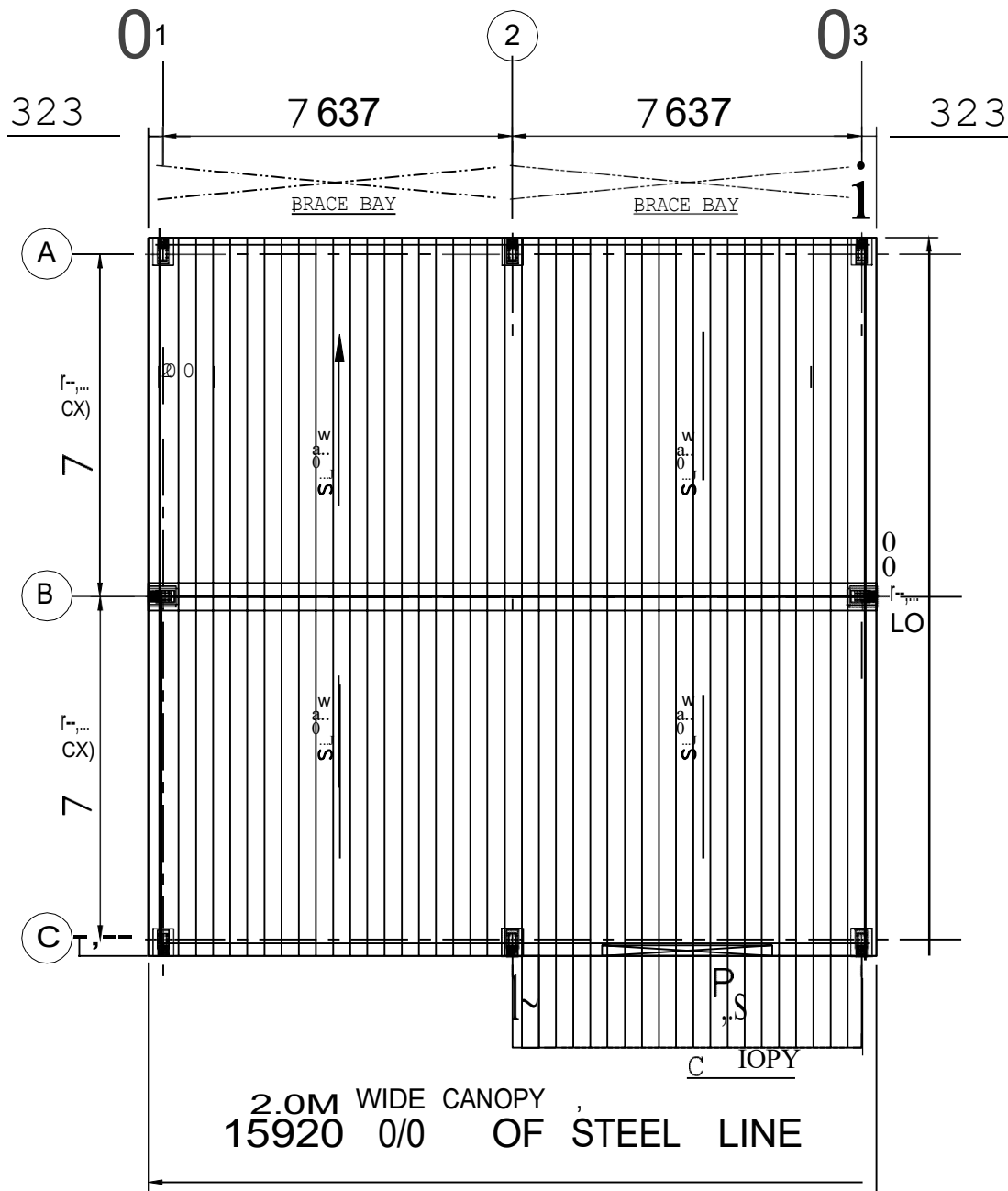

LAYOUT PLAN

TENDER DRAWING		DRAWING TITLE :- ROOF PLAN (MACHINE SHADE)	
PROJECT :- PROPOSED PEB SHED FOR MANDHAL AGRO PRODUCT FARMERS PRODUCER COMPANY LIMITED, DIST- NAGPUR		DRAWING NUMBER 23/SP/SMART-01/NGP/TRO/1/W	SERIAL NUMBER 5
STRUCTURAL CONSULTANT :- A&A ASSOCIATES, NANDED. ABHAY O LOKMANWAR M.E.STRUCTURAL		DESIGN BY :- A.L.	REV NO. :- RO
		DRAWN BY :- VJB	SCALE :- NTS
		CHECKED BY :- NAGESH	DATE :- 28/05/23
		APPROVED BY: A.L.	

NOTES

1. THIS DRAWING IS TO BE READ IN CONJUNCTION WITH ALL OTHER RELEVANT ARCHITECTURAL AND STRUCTURAL DRAWINGS.
2. ALL DIMENSIONS ARE IN MILLIMETERS AND LEVELS ARE IN METERS UNLESS NOTED OTHERWISE.
3. DO NOT SCALE THE DRAWING.
4. ALL HOT ROLLED MEMBERS SHALL CONFORM TO BSEN 10025-S275 OR EQUIVALENT & OF GRADE Y.S. 345 N/SQMM
5. ALL THE BUILT UP MEMBERS SHALL CONFORM TO ASTM A572 OR BSEN 10025-S355
6. ALL WELDS ARE AWS STANDARD UNLESS OTHERWISE NOTED.
7. BOLTS FOR MAIN STRUCTURAL CONNECTIONS ARE ASTM A325
8. BOLTS FOR BRACINGS, PURLINS, GIRTS ETC. ARE GRADE 4.6
9. PAINTING SYSTEM AND ALL OTHER TERMS AS PER CONTRACTS.

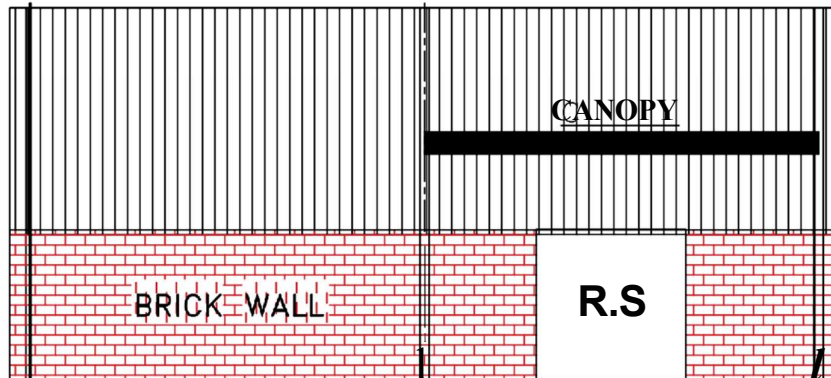

ELEVATION FOR GRID A

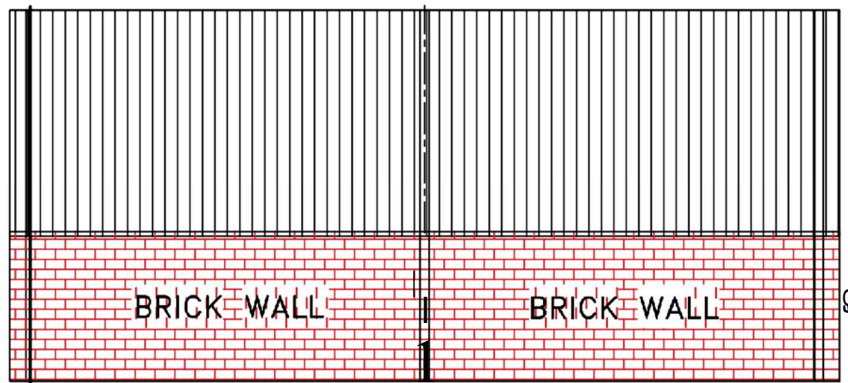

ELEVATION FOR GRID C

TENDER DRAWING		DRAWING TITLE :- LAYOUT PLAN (MACHINE SHADE)	
PROJECT :- PROPOSED PEB SHED FOR MANDHAL AGRO PRODUCT FARMERS PRODUCER COMPANY LIMITED, DIST- NAGPUR	DRAWING NUMBER 23/SP/SMART-01/NGP/TROI/M	SERIAL NUMBER 6	REV NO. :- RO
STRUCTURAL CONSULTANT :- A&A ASSOCIATES, NANDED. ABHAY O LOKMANWAR M.E.STRUCTURAL	DESIGN BY :- A.L.	DRAWN BY :- VJB	SCALE :- NTS
	CHECKED BY :- NAGESH	DATE :- 28/05/23	APPROVED BY. A.L.